

Introducing the Autobag® 550™ Bagging System – Next generation bagging that optimizes flexibility for ecommerce order fulfillment, short-run, and build-on-demand operations

The Autobag® 550™ is a technologically-advanced, automatic filling and sealing machine designed for reliability, flexibility and optimizing packaging throughput. Capable of cycling at speeds up to 45 bags per minute, this system delivers maximum machine uptime while lowering total cost of ownership.

Next-bag-out printing is achieved with an advanced thermal transfer imprinter positioned directly over the next bag to be loaded. This ensures accuracy and efficiency in applications that require frequent product and label changeovers, prevents product queuing and eliminates a separate labeling operation.

State-of-the-art engineering has led to an inherently safe and flexible design. No light curtains or double palm switches are required to achieve safe hand-load operation. The Autobag 550 is configurable for left- or right-hand access to the HMI, cycle switch, and ribbon and bag loading areas, improving ergonomics and operator productivity. Plus, the Autobag 550 can be networked to facilitate full pack station integration and central monitoring. A 45 degree tilt option is available for orienting long or delicate products.

A straightforward, simple design with very few moving parts reduces lifetime cost and improves reliability, while on-board diagnostics and modular components simplify maintenance.

When used with genuine Autobag pre-opened bags-on-a-roll or bags-in-a-box if applicable, and AutoLabel Thermal Transfer Ribbon, the Autobag 550 ushers in the next evolution of high-quality, reliable and flexible bag packaging, backed by the industry's most comprehensive engineering and field service network.

Markets Served

- Mail Order and ecommerce Fulfillment
- Prescription-by-mail Fulfillment
- Catalog Order Fulfillment
- Spare Parts Distribution
- Short-run production with frequent changeovers in any market



Next-bag-out printing prevents product queuing and reduces waste



Multi-position unwind with tension control simplifies changeover



AutoTouch™ Control Screen accesses operator tutorials, help system, on-board diagnostics, and performance monitoring



Newly designed bag sealer area combined with improved temperature control and optional seal-flatteners ensure consistent, high-quality seals

Features and Benefits

More Options

More bag size options; from 2" W x 2.5" L to 12" W x 20" L supported (36" long unsupported)

Streamlined

Processor controlled servo motors, ethernet-capable networking, and flexible mechanical design streamline integration

Compact

Compact footprint minimizes floor space

Adjustable

Simple height adjustment and casters for operator comfort and portability

Configuration Options

A 45 degree tilt option is available for orienting long or delicate products



Flexible

Adjustable pass-through up to 5" for maximum flexibility and packaging efficiency



Integration

Easily integrates with third-party systems for mail order fulfillment applications



Serviceability

Modular components and dedicated service access simplify maintenance and repairs to maximize uptime



System Matched Bags



Service & Support



Custom Engineering & Integration

Optional Additions

- Handheld or Tabletop Bar Code Scanner
- Range of Infeed Funnels
- Seal Flatteners
- Raised Unwind
- SimpleCount™ Counting System
- Bags-in-a-box Adapter

Technical Information

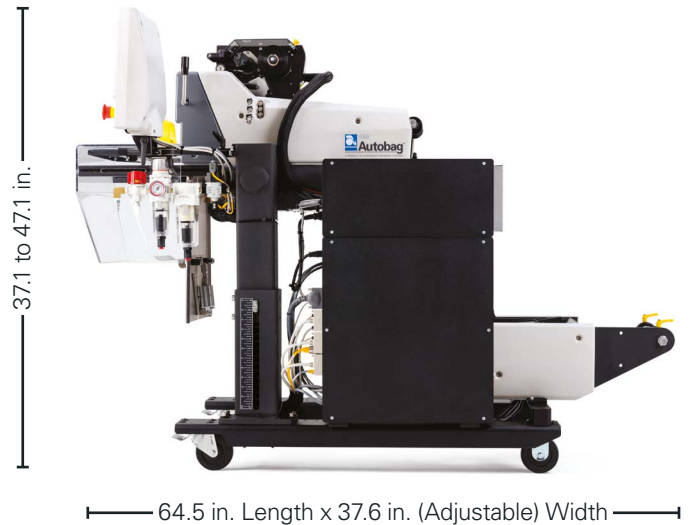

Weight	390 lbs.
Electrical	Universal Input: 110V to 240V VAC, 50/60 Hz Power Consumption: 1500 Watts (VA) max
Air Feed	5 CFM/80 psi of clean, dry air
Pass-Through	5 in. max
Bag Thickness	1.09 – 4.0 mil
Bag Sizes	W 2 to 12 in. L 5 to 20 in. (36 in. L unsupported)
Weight Capacity	Up to 5 lbs. (with load shelf)

DOVERCO
Strategic. Packaging.

2111 32nd Avenue, Montreal, Quebec H8T 3J1
Tel: (514) 420-6060 • Fax: (514) 420-6015
250 Trowers Road, Unit 7, Vaughan, Ontario L4L 5Z6
Tel: (289) 256-2141 • Fax: (289) 256-2142
Toll Free: 1-800-363-0697 • www.doverco.ca • sales@doverco.ca

 **Automated**
PACKAGING SYSTEMS